

XL marlin Lighting

Weatherproof Light (XLCL320BL) Installation Instruction

The user: thank you for your purchase use this product, read this instruction manual before usage

1. Model: XLCL320BL
2. Rated Voltage: 220-240V
3. Rated Power : 24W
4. IP Grade: IP65
5. Insulation protection level: Class I
6. Operating Temperature: -20° - +40°

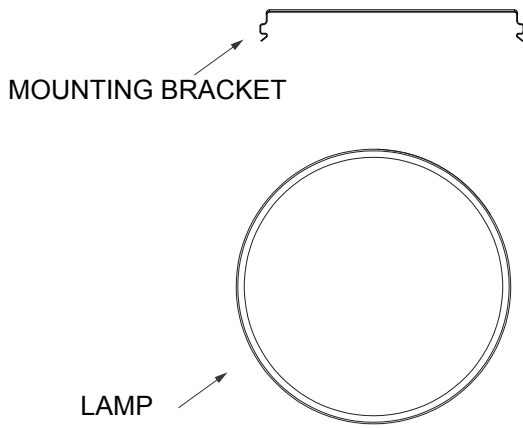
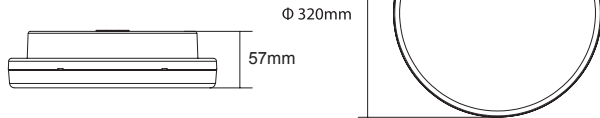

- Always disconnect the power supply before installing or performing any maintenance operations.
- Installation should be carried out by a suitably qualified person in accordance with good electrical practice and the appropriate national wiring regulations.
- These luminaires are widely used in commercial lighting, home decoration lighting, art gallery and museums.
- Only can be touched after 3 minutes later when power off, so as to avoid burns.
- Dismantling and refit are forbidden
- Installation on inflammables is forbidden.

If the external flexible cable or cord of this luminaire is damaged, it shall be exclusively replaced by the manufacturer or his service agent or a similar qualified person in order to avoid a hazard.

1. INSTALL THE LIGHT MOUNTING BRACKET on the location, make sure the screws be fixed tightly.

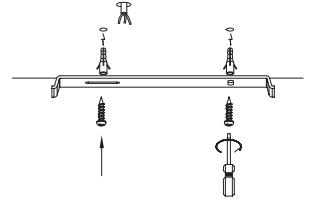

2. CONNECT THE CABLE .
 - Open the junction box in the back of the lamp

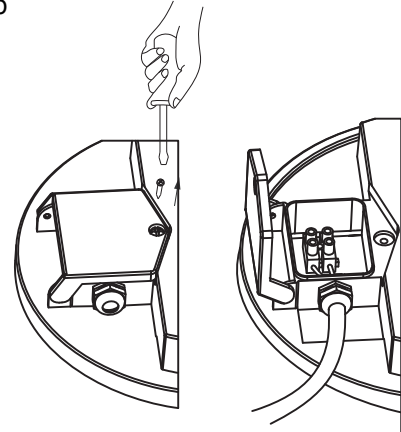

- Live line for L terminal,
- Null line for N terminal,
- Ground line for E terminal.

3. PUSH THE FIXTURE INTO MOUNTING BRACKET

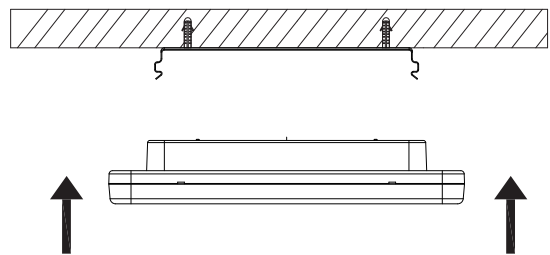

4. CONNECT THE POWER SUPPLY, light up the lamp.

The light source of this luminaire is not replaceable; when the source reaches its end of life the whole luminaire shall be replaced

Welcome you again to buy our products