

XL marlin Lighting

Exterior Street Light (OLS10B) Installation Instruction

The user: thank you for your purchase use this product, read this instruction manual before usage

1. Model: OLS10B
2. Rated Voltage: AC 100~240V
3. Rated Power : 80 W
4. IP Grade: IP66
5. Insulation protection level: Class III
6. Operating Temperature: -35~50°C°

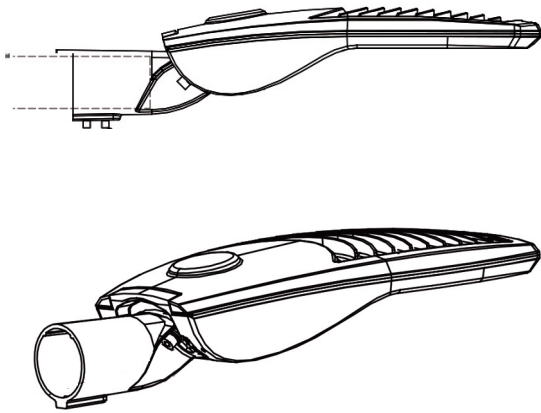

- Always disconnect the power supply before installing or performing any maintenance operations.
- Installation should be carried out by a suitably qualified person in accordance with good electrical practice and the appropriate national wiring regulations.
- These luminaires are widely used in commercial lighting, home decoration lighting, art gallery and museums.
- Only can be touched after 3 minutes later when power off, so as to avoid burns.
- Dismantling and refit are forbidden
- Installation on inflammables is forbidden.

If the external flexible cable or cord of this luminaire is damaged, it shall be exclusively replaced by the manufacturer or his service agent or a similar qualified person in order to avoid a hazard.

1. OPEN COVER

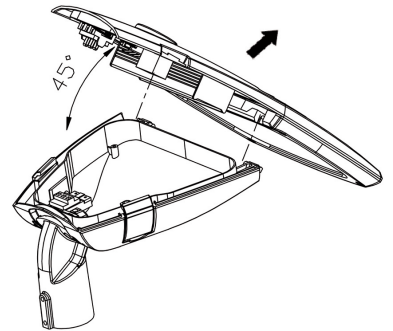

- ### 2. CONNECT THE CABLE .
- Live line for L terminal,
Null line for N terminal,
Ground line for E terminal.

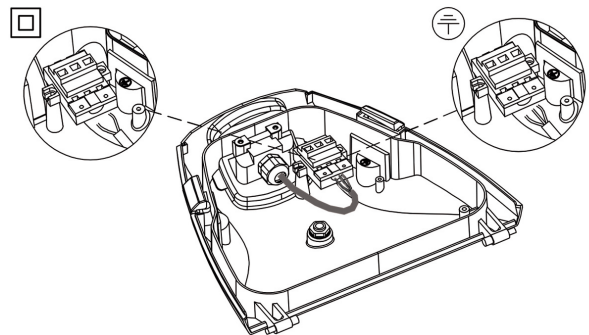

3. FIX STREET LIGHTS TO POLE

Make sure the screws be fixed tightly.

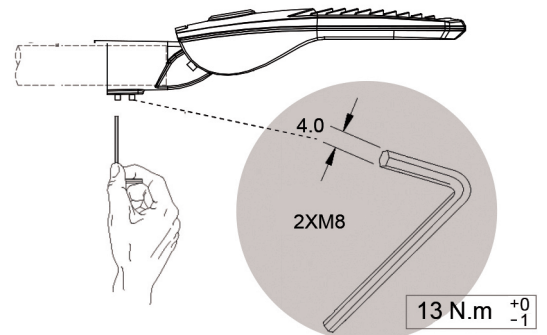

- ### 5. CONNECT THE POWER SUPPLY , light up the lamp.