

XL marlin Lighting

Street Light (OLSL11S) Installation Instruction

The user: thank you for your purchase use this product, read this instruction manual before usage

- 1.Model: OLSL11S
- 2.Rated Voltage: 90-305VAC/50-60Hz
- 3.Rated Power : 50W / 70W / 90W
- 4.IP Grade: IP65
- 5.Operating Temperature:-30 to +45

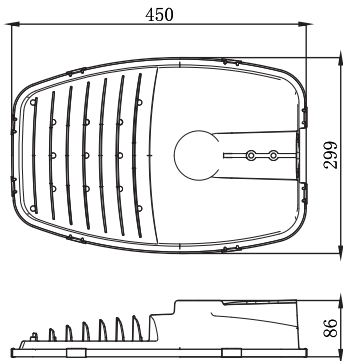

- Always disconnect the power supply before installing or performing any maintenance operations.
- Installation should be carried out by a suitably qualified person in accordance with good electrical practice and the appropriate national wiring regulations.
- These luminaires are widely used in commercial lighting, home decoration lighting, art gallery and museums.
- Only can be touched after 3 minutes later when power off, so as to avoid burns.
- Dismantling and refit are forbidden
- Installation on inflammables is forbidden.

If the external flexible cable or cord of this luminaire is damaged, it shall be exclusively replaced by the manufacturer or his service agent or a similar qualified person in order to avoid a hazard.

1. Insert the Bracket into the pole, fasten the mounting screws.

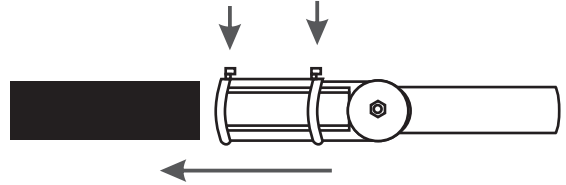

2. Adjust the rotary angle to required angle.

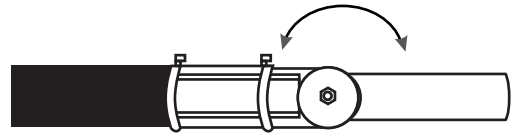

- 3.Remove the mounting screws, using 6mm key

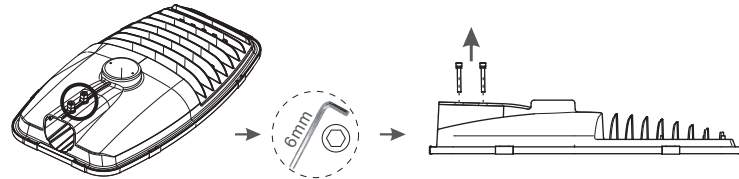

4. Connect supply wires to luminaire wire leads per the wiring diagram .

Live line for L terminal,
Null line for N terminal,
Ground line for E terminal.

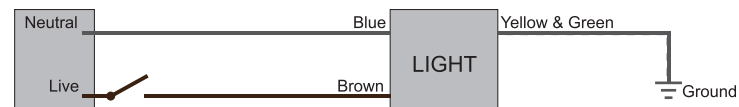

5. Insert the lamp into the Bracket , fasten the mounting screws.

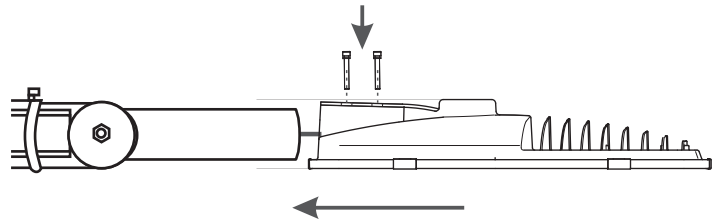

6. Connect the power supply, light up the lamp.

The light source of this luminaire is not replaceable; when the source reaches its end of life the whole luminaire shall be replaced

Welcome you again to buy our products