

Model: XLQD150



General Data

| | |
|--------------|---------------|
| Lamp Type | 3030 2D |
| System Watts | 150 W |
| Lumens | 22500 lm |
| Lamp Life | 50000 hrs |
| CRI | >80 Ra |
| IP Rating | IP 65 |
| Weight (Kgs) | 6.7 Kgs |
| Voltage | 110-240V |
| Dimming | 1-10 W / DALI |
| CCT | 3000/5700K |
| Oper. temp. | -40 to +50 |

Construction Data

| | |
|----------------------|---|
| IP rating | 65 waterproof |
| Housing | Die-cast Aluminum |
| Protection finishing | AkzoNobel Powder-coated black colour finish |
| Glass | Tempered glass diffuser |
| Loading capacity | / |
| Cable Gland | IP65 |
| Gasket | Silicone rubber gasket |

Electrical Data

| | |
|---------------|---------------------------------|
| Input voltage | AC100-240V |
| Cable | Cable gland for waterproof IP65 |

Accessories

| | |
|---------|---------------|
| Bracket | Angle Bracket |
| Clip | / |

APPLICATIONS

Suitable for Warehouses, Workshops, Gymnasiums, Gas Stations, Toll Stations, Supermarkets, Exhibition halls and many other Industrial and commercial lighting applications.

PRODUCT DESCRIPTION

LED Modular flood light, 5 years warranty, Osram/ Lumileds LED, Meanwell Driver, Diecast Aluminum body with Stainless steel screws. Available in multiple dimming options such as Dali, 1-10V Dimming.

FIXTURE CONSTRUCTION

Die cast Aluminum body, powerful thermal dissipation and IP65 waterproof performance. Available in other colours, die cast aluminum heat sink.

Dimension Drawing

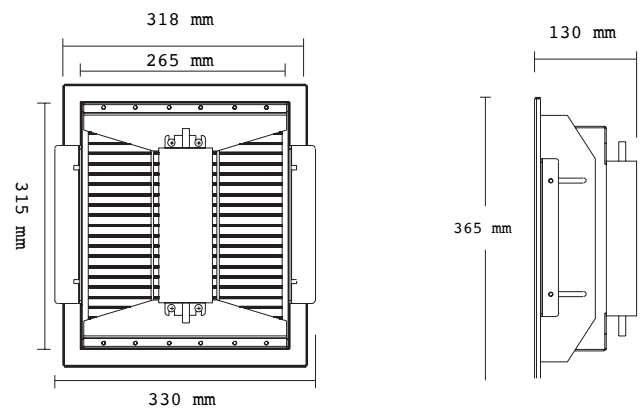

Lamp Options

| Part Number | CCT | Beam angle |
|-------------|--------|------------|
| XLQD150360 | 3000 K | 60° |
| XLQD150460 | 7500 K | 60° |
| XLQD150390 | 3000 K | 90° |
| XLQD150490 | 7500 K | 90° |
| XLQD1503110 | 3000 K | 110° |
| XLQD1504110 | 7500 K | 110° |

Photometric Data

Light Distribution Curve

